



**COMMONWEALTH OF PENNSYLVANIA
DEPARTMENT OF ENVIRONMENTAL PROTECTION
AIR QUALITY PROGRAM**

STATE ONLY SYNTHETIC MINOR OPERATING PERMIT

Issue Date:	March 10, 2016	Effective Date:	March 2, 2023
Revision Date:	March 2, 2023	Expiration Date:	March 9, 2027
Revision Type:	Amendment		

In accordance with the provisions of the Air Pollution Control Act, the Act of January 8, 1960, P.L. 2119, as amended, and 25 Pa. Code Chapter 127, the Owner, [and Operator if noted] (hereinafter referred to as permittee) identified below is authorized by the Department of Environmental Protection (Department) to operate the air emission source(s) more fully described in this permit. This Facility is subject to all terms and conditions specified in this permit. Nothing in this permit relieves the permittee from its obligations to comply with all applicable Federal, State and Local laws and regulations.

The regulatory or statutory authority for each permit condition is set forth in brackets. All terms and conditions in this permit are federally enforceable unless otherwise designated.

State Only Permit No: 09-00152

Synthetic Minor

Federal Tax Id - Plant Code: 23-2499368-1

Owner Information

Name: GELEST INC
Mailing Address: 11 STEEL RD E
MORRISVILLE, PA 19067-3613

Plant Information

Plant: GELEST INC/FALLS TWP
Location: 09 Bucks County 09002 Falls Township
SIC Code: 2869 Manufacturing - Industrial Organic Chemicals, Nec

Responsible Official

Name: NEVILLE LOCKWOOD
Title: SVP, OPERATIONS
Phone: (215) 547 - 1015 Ext.347 Email: nlockwood@gelest.com

Permit Contact Person

Name: SHELLY KEARNEY
Title: REGULATORY AFFAIRS DIR
Phone: (215) 547 - 1015 Ext.424 Email: skearney@gelest.com

[Signature] _____
JAMES D. REBARCHAK, SOUTHEAST REGION AIR PROGRAM MANAGER



SECTION A. Table of Contents

Section A. Facility/Source Identification

Table of Contents
Site Inventory List

Section B. General State Only Requirements

- #001 Definitions.
- #002 Operating Permit Duration.
- #003 Permit Renewal.
- #004 Operating Permit Fees under Subchapter I.
- #005 Transfer of Operating Permits.
- #006 Inspection and Entry.
- #007 Compliance Requirements.
- #008 Need to Halt or Reduce Activity Not a Defense.
- #009 Duty to Provide Information.
- #010 Revising an Operating Permit for Cause.
- #011 Operating Permit Modifications
- #012 Severability Clause.
- #013 De Minimis Emission Increases.
- #014 Operational Flexibility.
- #015 Reactivation
- #016 Health Risk-based Emission Standards and Operating Practice Requirements.
- #017 Circumvention.
- #018 Reporting Requirements.
- #019 Sampling, Testing and Monitoring Procedures.
- #020 Recordkeeping.
- #021 Property Rights.
- #022 Alternative Operating Scenarios.
- #023 Reporting
- #024 Report Format

Section C. Site Level State Only Requirements

- C-I: Restrictions
- C-II: Testing Requirements
- C-III: Monitoring Requirements
- C-IV: Recordkeeping Requirements
- C-V: Reporting Requirements
- C-VI: Work Practice Standards
- C-VII: Additional Requirements
- C-VIII: Compliance Certification
- C-IX: Compliance Schedule

Section D. Source Level State Only Requirements

- D-I: Restrictions
- D-II: Testing Requirements
- D-III: Monitoring Requirements
- D-IV: Recordkeeping Requirements
- D-V: Reporting Requirements
- D-VI: Work Practice Standards
- D-VII: Additional Requirements

Note: These same sub-sections are repeated for each source!

Section E. Source Group Restrictions

- E-I: Restrictions



SECTION A. Table of Contents

- E-II: Testing Requirements
- E-III: Monitoring Requirements
- E-IV: Recordkeeping Requirements
- E-V: Reporting Requirements
- E-VI: Work Practice Standards
- E-VII: Additional Requirements

Section F. Alternative Operating Scenario(s)

- F-I: Restrictions
- F-II: Testing Requirements
- F-III: Monitoring Requirements
- F-IV: Recordkeeping Requirements
- F-V: Reporting Requirements
- F-VI: Work Practice Standards
- F-VII: Additional Requirements

Section G. Emission Restriction Summary

Section H. Miscellaneous



SECTION A. Site Inventory List

Source ID	Source Name	Capacity/Throughput	Fuel/Material
101	REACTORS		
103A	EXEMPT EMERGENCY GENERATOR		
103B	TWO EXEMPT EMERGENCY GENERATORS		
CD1	CONDENSER		
CD2	ACID GAS SCRUBBER (DUALL)		
CD3	BASE GAS SCRUBBER		
CD4	DUST COLLECTOR		
CD5	ACID GAS SCRUBBER(VERANTIS)		
CD6	CHILLED DEWAR TRAP		
FML01	DIESEL FUEL		
S01	ACID SCRUBBER STACK (DUALL)		
S02	BASE SCRUBBER STACK		
S103A	EG1 EMERGENCY GENERATOR STACK		
S103B	EG2 EMERGENCY GENERTOR STACK		
S103C	EG3 EMERGENCY GENERATOR STACK		
SO4	ACID GAS SCRUBBER STACK(VERANTIS)		

PERMIT MAPS

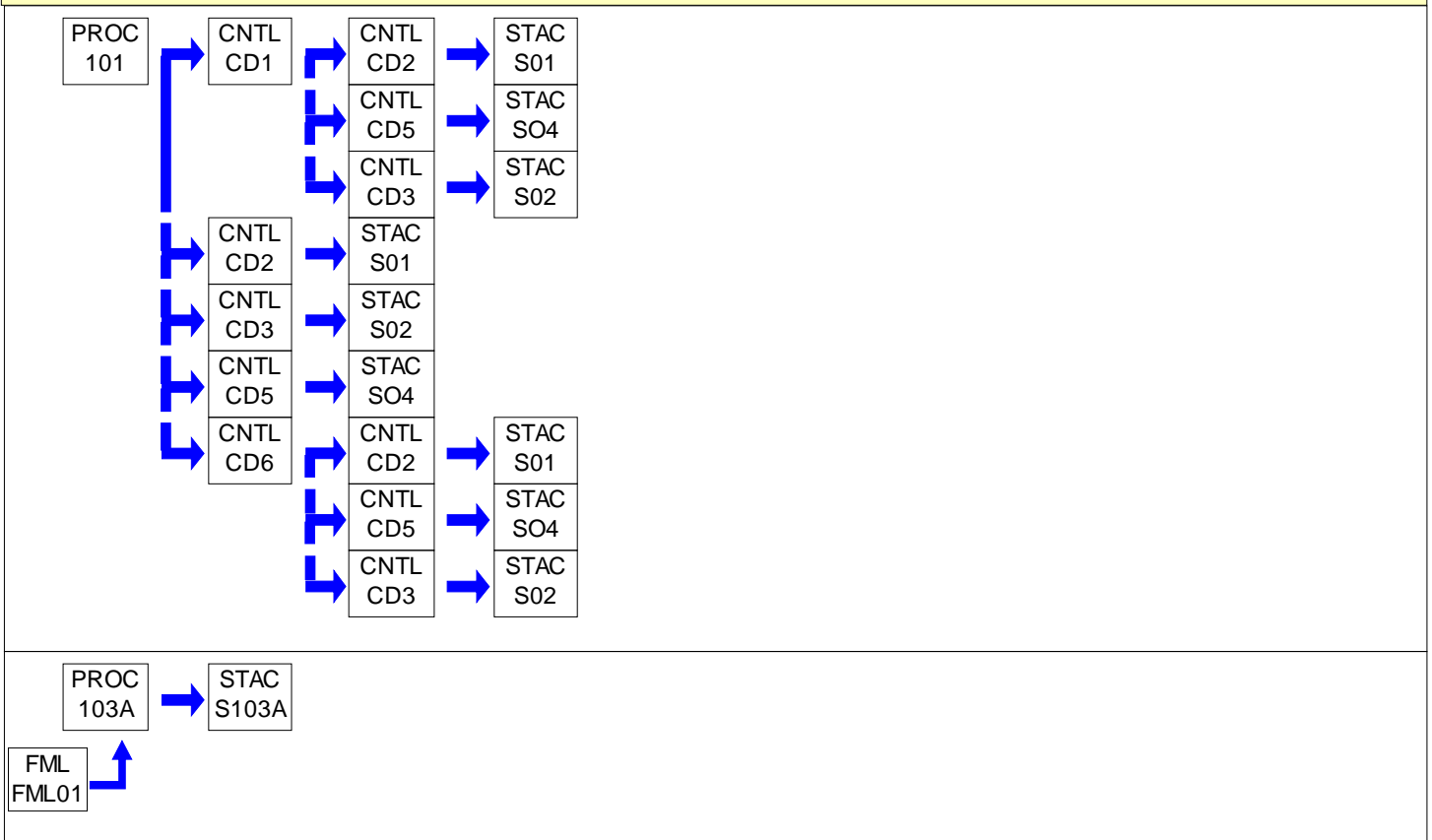



PERMIT MAPS

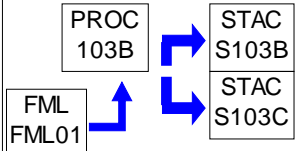

**SECTION B. General State Only Requirements****#001 [25 Pa. Code § 121.1]****Definitions.**

Words and terms that are not otherwise defined in this permit shall have the meanings set forth in Section 3 of the Air Pollution Control Act (35 P.S. § 4003) and in 25 Pa. Code § 121.1.

#002 [25 Pa. Code § 127.446]**Operating Permit Duration.**

(a) This operating permit is issued for a fixed term of five (5) years and shall expire on the date specified on Page 1 of this permit.

(b) The terms and conditions of the expired permit shall automatically continue pending issuance of a new operating permit, provided the permittee has submitted a timely and complete application and paid applicable fees required under 25 Pa. Code Chapter 127, Subchapter I and the Department is unable, through no fault of the permittee, to issue or deny a new permit before the expiration of the previous permit.

#003 [25 Pa. Code §§ 127.412, 127.413, 127.414, 127.446 & 127.703(b)]**Permit Renewal.**

(a) The permittee shall submit a timely and complete application for renewal of the operating permit to the appropriate Regional Air Program Manager. The application for renewal of the operating permit shall be submitted at least six (6) months and not more than 18 months before the expiration date of this permit.

(b) The application for permit renewal shall include the current permit number, a description of any permit revisions that occurred during the permit term, and any applicable requirements that were promulgated and not incorporated into the permit during the permit term. An application is complete if it contains sufficient information to begin processing the application, has the applicable sections completed and has been signed by a responsible official.

(c) The permittee shall submit with the renewal application a fee for the processing of the application as specified in 25 Pa. Code § 127.703(b). The fees shall be made payable to "The Commonwealth of Pennsylvania Clean Air Fund" and submitted with the fee form to the respective regional office.

(d) The renewal application shall also include submission of proof that the local municipality and county, in which the facility is located, have been notified in accordance with 25 Pa. Code § 127.413.

(e) The application for renewal of the operating permit shall also include submission of supplemental compliance review forms in accordance with the requirements of 25 Pa. Code § 127.412(b) and § 127.412(j).

(f) The permittee, upon becoming aware that any relevant facts were omitted or incorrect information was submitted in the permit application, shall promptly submit such supplementary facts or corrected information as necessary to address any requirements that become applicable to the source after the permittee submits a complete application, but prior to the date the Department takes action on the permit application.

#004 [25 Pa. Code § 127.703]**Operating Permit Fees under Subchapter I.**

(a) The permittee shall pay the annual operating permit maintenance fee according to the following fee schedule in either paragraph (1) or (2) in accordance with 25 Pa. Code § 127.703(d) on or before December 31 of each year for the next calendar year.

(1) For a synthetic minor facility, a fee equal to:

(i) Four thousand dollars (\$4,000) for calendar years 2021—2025.

(ii) Five thousand dollars (\$5,000) for calendar years 2026—2030.

(iii) Six thousand three hundred dollars (\$6,300) for the calendar years beginning with 2031.

**SECTION B. General State Only Requirements**

(2) For a facility that is not a synthetic minor, a fee equal to:

- (i) Two thousand dollars (\$2,000) for calendar years 2021—2025.
- (ii) Two thousand five hundred dollars (\$2,500) for calendar years 2026—2030.
- (iii) Three thousand one hundred dollars (\$3,100) for the calendar years beginning with 2031.

(b) The applicable fees shall be made payable to "The Commonwealth of Pennsylvania Clean Air Fund" with the permit number clearly indicated and submitted to the respective regional office.

#005 [25 Pa. Code §§ 127.450 (a)(4) and 127.464]**Transfer of Operating Permits.**

(a) This operating permit may not be transferred to another person, except in cases of transfer-of-ownership that are documented and approved by the Department.

(b) In accordance with 25 Pa. Code § 127.450(a)(4), a change in ownership of the source shall be treated as an administrative amendment if the Department determines that no other change in the permit is required and a written agreement has been submitted to the Department identifying the specific date of the transfer of permit responsibility, coverage and liability between the current and the new permittee and a compliance review form has been submitted to, and the permit transfer has been approved by, the Department.

(c) This operating permit is valid only for those specific sources and the specific source locations described in this permit.

#006 [25 Pa. Code § 127.441 and 35 P.S. § 4008]**Inspection and Entry.**

(a) Upon presentation of credentials and other documents as may be required by law, the permittee shall allow the Department or authorized representatives of the Department to perform the following:

(1) Enter at reasonable times upon the permittee's premises where a source is located or emissions related activity is conducted, or where records are kept under the conditions of this permit;

(2) Have access to and copy, at reasonable times, any records that are kept under the conditions of this permit;

(3) Inspect at reasonable times, any facilities, equipment including monitoring and air pollution control equipment, practices, or operations regulated or required under this permit;

(4) Sample or monitor, at reasonable times, any substances or parameters, for the purpose of assuring compliance with the permit or applicable requirements as authorized by the Clean Air Act, the Air Pollution Control Act, or the regulations promulgated under the Acts.

(b) Pursuant to 35 P.S. § 4008, no person shall hinder, obstruct, prevent or interfere with the Department or its personnel in the performance of any duty authorized under the Air Pollution Control Act or regulations adopted thereunder including denying the Department access to a source at this facility. Refusal of entry or access may constitute grounds for permit revocation and assessment of criminal and/or civil penalties.

(c) Nothing in this permit condition shall limit the ability of the EPA to inspect or enter the premises of the permittee in accordance with Section 114 or other applicable provisions of the Clean Air Act.

#007 [25 Pa. Code §§ 127.441 & 127.444]**Compliance Requirements.**

(a) The permittee shall comply with the conditions of this operating permit. Noncompliance with this permit constitutes a violation of the Clean Air Act and the Air Pollution Control Act and is grounds for one or more of the following:

**SECTION B. General State Only Requirements**

- (1) Enforcement action
- (2) Permit termination, revocation and reissuance or modification
- (3) Denial of a permit renewal application

(b) A person may not cause or permit the operation of a source which is subject to 25 Pa. Code Article III unless the source(s) and air cleaning devices identified in the application for the plan approval and operating permit and the plan approval issued for the source is operated and maintained in accordance with specifications in the applications and the conditions in the plan approval and operating permit issued by the Department. A person may not cause or permit the operation of an air contamination source subject to 25 Pa. Code Chapter 127 in a manner inconsistent with good operating practices.

(c) For purposes of Sub-condition (b) of this permit condition, the specifications in applications for plan approvals and operating permits are the physical configurations and engineering design details which the Department determines are essential for the permittee's compliance with the applicable requirements in this State-Only permit. Nothing in this sub-condition shall be construed to create an independent affirmative duty upon the permittee to obtain a predetermination from the Department for physical configuration or engineering design detail changes made by the permittee.

#008 [25 Pa. Code § 127.441]**Need to Halt or Reduce Activity Not a Defense.**

It shall not be a defense for the permittee in an enforcement action that it was necessary to halt or reduce the permitted activity in order to maintain compliance with the conditions of this permit.

#009 [25 Pa. Code §§ 127.442(a) & 127.461]**Duty to Provide Information.**

(a) The permittee shall submit reports to the Department containing information the Department may prescribe relative to the operation and maintenance of each source at the facility.

(b) The permittee shall furnish to the Department, in writing, information that the Department may request to determine whether cause exists for modifying, revoking and reissuing, or terminating this permit, or to determine compliance with the permit. Upon request, the permittee shall also furnish to the Department copies of records that the permittee is required to maintain in accordance with this permit.

#010 [25 Pa. Code § 127.461]**Revising an Operating Permit for Cause.**

This operating permit may be terminated, modified, suspended or revoked and reissued if one or more of the following applies:

- (1) The permittee constructs or operates the source subject to the operating permit so that it is in violation of the Air Pollution Control Act, the Clean Air Act, the regulations thereunder, a plan approval, a permit or in a manner that causes air pollution.
- (2) The permittee fails to properly or adequately maintain or repair an air pollution control device or equipment attached to or otherwise made a part of the source.
- (3) The permittee has failed to submit a report required by the operating permit or an applicable regulation.
- (4) The EPA determines that the permit is not in compliance with the Clean Air Act or the regulations thereunder.

#011 [25 Pa. Code §§ 127.450, 127.462, 127.465 & 127.703]**Operating Permit Modifications**

(a) The permittee is authorized to make administrative amendments, minor operating permit modifications and significant operating permit modifications, under this permit, as outlined below:

**SECTION B. General State Only Requirements**

(b) Administrative Amendments. The permittee shall submit the application for administrative operating permit amendments (as defined in 25 Pa. Code § 127.450(a)), according to procedures specified in § 127.450 unless precluded by the Clean Air Act or its regulations.

(c) Minor Operating Permit Modifications. The permittee shall submit the application for minor operating permit modifications (as defined 25 Pa. Code § 121.1) in accordance with 25 Pa. Code § 127.462.

(d) Significant Operating Permit Modifications. The permittee shall submit the application for significant operating permit modifications in accordance with 25 Pa. Code § 127.465.

(e) The applicable fees shall be made payable to "The Commonwealth of Pennsylvania Clean Air Fund" with the permit number clearly indicated and submitted to the respective regional office.

#012 [25 Pa. Code § 127.441]**Severability Clause.**

The provisions of this permit are severable, and if any provision of this permit is determined by a court of competent jurisdiction to be invalid or unenforceable, such a determination will not affect the remaining provisions of this permit.

#013 [25 Pa. Code § 127.449]**De Minimis Emission Increases.**

(a) This permit authorizes de minimis emission increases in accordance with 25 Pa. Code § 127.449 so long as the permittee provides the Department with seven (7) days prior written notice before commencing any de minimis emissions increase. The written notice shall:

(1) Identify and describe the pollutants that will be emitted as a result of the de minimis emissions increase.

(2) Provide emission rates expressed in tons per year and in terms necessary to establish compliance consistent with any applicable requirement.

(b) The Department may disapprove or condition de minimis emission increases at any time.

(c) Except as provided below in (d), the permittee is authorized to make de minimis emission increases (expressed in tons per year) up to the following amounts without the need for a plan approval or prior issuance of a permit modification:

(1) Four tons of carbon monoxide from a single source during the term of the permit and 20 tons of carbon monoxide at the facility during the term of the permit.

(2) One ton of NO_x from a single source during the term of the permit and 5 tons of NO_x at the facility during the term of the permit.

(3) One and six-tenths tons of the oxides of sulfur from a single source during the term of the permit and 8.0 tons of oxides of sulfur at the facility during the term of the permit.

(4) Six-tenths of a ton of PM₁₀ from a single source during the term of the permit and 3.0 tons of PM₁₀ at the facility during the term of the permit. This shall include emissions of a pollutant regulated under Section 112 of the Clean Air Act unless precluded by the Clean Air Act, the regulations thereunder or 25 Pa. Code Article III.

(5) One ton of VOCs from a single source during the term of the permit and 5.0 tons of VOCs at the facility during the term of the permit. This shall include emissions of a pollutant regulated under Section 112 of the Clean Air Act unless precluded by the Clean Air Act, the regulations thereunder or 25 Pa. Code Article III.

(6) Other sources and classes of sources determined to be of minor significance by the Department.

(d) In accordance with § 127.14, the permittee is authorized to install the following minor sources without the need for a plan approval or permit modification:

**SECTION B. General State Only Requirements**

(1) Air conditioning or ventilation systems not designed to remove pollutants generated or released from other sources.

(2) Combustion units rated at 2,500,000 or less Btu per hour of heat input.

(3) Combustion units with a rated capacity of less than 10,000,000 Btu per hour heat input fueled by natural gas supplied by a public utility or by commercial fuel oils which are No. 2 or lighter, viscosity less than or equal to 5.82 c St, and which meet the sulfur content requirements of 25 Pa. Code §123.22 (relating to combustion units). For purposes of this permit, commercial fuel oil shall be virgin oil which has no reprocessed, recycled or waste material added.

(4) Space heaters which heat by direct heat transfer.

(5) Laboratory equipment used exclusively for chemical or physical analysis.

(6) Other sources and classes of sources determined to be of minor significance by the Department.

(e) This permit does not authorize de minimis emission increases if the emissions increase would cause one or more of the following:

(1) Increase the emissions of a pollutant regulated under Section 112 of the Clean Air Act except as authorized in Subparagraphs (c)(4) and (5) of this permit condition.

(2) Subject the facility to the prevention of significant deterioration requirements in 25 Pa. Code Chapter 127, Subchapter D and/or the new source review requirements in Subchapter E.

(3) Violate any applicable requirement of this permit, the Air Pollution Control Act, the Clean Air Act, or the regulations promulgated under either of the acts.

(f) Emissions authorized under this permit condition shall be included in the monitoring, recordkeeping and reporting requirements of this permit.

(g) Except for de minimis emission increases, installation of minor sources made pursuant to this permit condition and Plan Approval Exemptions under 25 Pa. Code § 127.14 (relating to exemptions), the permittee is prohibited from making changes or engaging in activities that are not specifically authorized under this permit without first applying for a plan approval. In accordance with § 127.14(b), a plan approval is not required for the construction, modification, reactivation, or installation of the sources creating the de minimis emissions increase.

(h) The permittee may not meet de minimis emission threshold levels by offsetting emission increases or decreases at the same source.

#014 [25 Pa. Code § 127.3]**Operational Flexibility.**

The permittee is authorized to make changes within the facility in accordance with the regulatory provisions outlined in 25 Pa. Code § 127.3 (relating to operational flexibility) to implement the operational flexibility requirements provisions authorized under Section 6.1(i) of the Air Pollution Control Act and the operational flexibility terms and conditions of this permit. The provisions in 25 Pa. Code Chapter 127 which implement the operational flexibility requirements include the following:

(1) Section 127.14 (relating to exemptions)

(2) Section 127.447 (relating to alternative operating scenarios)

(3) Section 127.448 (relating to emissions trading at facilities with Federally enforceable emissions caps)

(4) Section 127.449 (relating to de minimis emission increases)

(5) Section 127.450 (relating to administrative operating permit amendments)

**SECTION B. General State Only Requirements**

(6) Section 127.462 (relating to minor operating permit modifications)

(7) Subchapter H (relating to general plan approvals and general operating permits)

#015 [25 Pa. Code § 127.11]**Reactivation**

(a) The permittee may not reactivate a source that has been out of operation or production for at least one year unless the reactivation is conducted in accordance with a plan approval granted by the Department or in accordance with reactivation and maintenance plans developed and approved by the Department in accordance with 25 Pa. Code § 127.11a(a).

(b) A source which has been out of operation or production for more than five (5) years but less than 10 years may be reactivated and will not be considered a new source if the permittee satisfies the conditions specified in 25 Pa. Code § 127.11a(b).

#016 [25 Pa. Code § 127.36]**Health Risk-based Emission Standards and Operating Practice Requirements.**

(a) When needed to protect public health, welfare and the environment from emissions of hazardous air pollutants from new and existing sources, the permittee shall comply with the health risk-based emission standards or operating practice requirements imposed by the Department, except as precluded by §§ 6.6(d)(2) and (3) of the Air Pollution Control Act [35 P.S. § 4006.6(d)(2) and (3)].

(b) A person challenging a performance or emission standard established by the Department has the burden to demonstrate that performance or emission standard does not meet the requirements of Section 112 of the Clean Air Act.

#017 [25 Pa. Code § 121.9]**Circumvention.**

No person may permit the use of a device, stack height which exceeds good engineering practice stack height, dispersion technique or other technique which, without resulting in reduction of the total amount of air contaminants emitted, conceals or dilutes an emission of air contaminants which would otherwise be in violation of 25 Pa. Code Article III, except that with prior approval of the Department, the device or technique may be used for control of malodors.

#018 [25 Pa. Code §§ 127.402(d) & 127.442]**Reporting Requirements.**

(a) The permittee shall comply with the applicable reporting requirements of the Clean Air Act, the regulations thereunder, the Air Pollution Control Act and 25 Pa. Code Article III including Chapters 127, 135 and 139.

(b) The permittee shall submit reports to the Department containing information the Department may prescribe relative to the operation and maintenance of any air contamination source.

(c) Reports, test data, monitoring data, notifications and requests for renewal of the permit shall be submitted to the:

Regional Air Program Manager
PA Department of Environmental Protection
(At the address given in the permit transmittal letter, or otherwise notified)

(d) Any records or information including applications, forms, or reports submitted pursuant to this permit condition shall contain a certification by a responsible official as to truth, accuracy and completeness. The certifications submitted under this permit shall require a responsible official of the facility to certify that based on information and belief formed after reasonable inquiry, the statements and information in the documents are true, accurate and complete.

(e) Any records, reports or information submitted to the Department shall be available to the public except for such

**SECTION B. General State Only Requirements**

records, reports or information which meet the confidentiality requirements of § 4013.2 of the Air Pollution Control Act and §§ 112(d) and 114(c) of the Clean Air Act. The permittee may not request a claim of confidentiality for any emissions data generated for the facility.

#019 [25 Pa. Code §§ 127.441(c) & 135.5]**Sampling, Testing and Monitoring Procedures.**

(a) The permittee shall comply with the monitoring, recordkeeping or reporting requirements of 25 Pa. Code Chapter 139 and the other applicable requirements of 25 Pa. Code Article III and additional requirements related to monitoring, reporting and recordkeeping required by the Clean Air Act and the regulations thereunder including the Compliance Assurance Monitoring requirements of 40 CFR Part 64, where applicable.

(b) Unless alternative methodology is required by the Clean Air Act and regulations adopted thereunder, sampling, testing and monitoring required by or used by the permittee to demonstrate compliance with any applicable regulation or permit condition shall be conducted in accordance with the requirements of 25 Pa. Code Chapter 139.

#020 [25 Pa. Code §§ 127.441(c) and 135.5]**Recordkeeping.**

(a) The permittee shall maintain and make available, upon request by the Department, the following records of monitored information:

- (1) The date, place (as defined in the permit) and time of sampling or measurements.
- (2) The dates the analyses were performed.
- (3) The company or entity that performed the analyses.
- (4) The analytical techniques or methods used.
- (5) The results of the analyses.
- (6) The operating conditions as existing at the time of sampling or measurement.

(b) The permittee shall retain records of any required monitoring data and supporting information for at least five (5) years from the date of the monitoring, sample, measurement, report or application. Supporting information includes the calibration data and maintenance records and original strip-chart recordings for continuous monitoring instrumentation, and copies of reports required by the permit.

(c) The permittee shall maintain and make available to the Department upon request, records including computerized records that may be necessary to comply with the reporting, recordkeeping and emission statement requirements in 25 Pa. Code Chapter 135 (relating to reporting of sources). In accordance with 25 Pa. Code Chapter 135, § 135.5, such records may include records of production, fuel usage, maintenance of production or pollution control equipment or other information determined by the Department to be necessary for identification and quantification of potential and actual air contaminant emissions.

#021 [25 Pa. Code § 127.441(a)]**Property Rights.**

This permit does not convey any property rights of any sort, or any exclusive privileges.

#022 [25 Pa. Code § 127.447]**Alternative Operating Scenarios.**

The permittee is authorized to make changes at the facility to implement alternative operating scenarios identified in this permit in accordance with 25 Pa. Code § 127.447.

**SECTION B. General State Only Requirements****#023 [25 Pa. Code §135.3]****Reporting**

(a) If the facility is a Synthetic Minor Facility, the permittee shall submit by March 1 of each year an annual emissions report for the preceding calendar year. The report shall include information for all active previously reported sources, new sources which were first operated during the preceding calendar year, and sources modified during the same period which were not previously reported. All air emissions from the facility should be estimated and reported.

(b) A source owner or operator of a Synthetic Minor Facility may request an extension of time from the Department for the filing of an annual emissions report, and the Department may grant the extension for reasonable cause.

#024 [25 Pa. Code §135.4]**Report Format**

If applicable, the emissions reports shall contain sufficient information to enable the Department to complete its emission inventory. Emissions reports shall be made by the source owner or operator in a format specified by the Department.

**SECTION C. Site Level Requirements****I. RESTRICTIONS.****Emission Restriction(s).****# 001 [25 Pa. Code §121.7]****Prohibition of air pollution.**

No person may permit air pollution as that term is defined in the Air Pollution Control Act (35 P.S. Section 4003).

002 [25 Pa. Code §123.1]**Prohibition of certain fugitive emissions**

(a) No person may permit the emission into the outdoor atmosphere of fugitive air contaminant from a source other than the following:

- (1) Construction or demolition of buildings or structures.
- (2) Grading, paving and maintenance of roads and streets.
- (3) Use of roads and streets. Emissions from material in or on trucks, railroad cars and other vehicular equipment are not considered as emissions from use of roads and streets.
- (4) Clearing of land.
- (5) Stockpiling of materials.
- (6) Open burning operations, as specified in 25 Pa. Code § 129.14.
- (7) N/A
- (8) N/A
- (9) Sources and classes of sources other than those identified in (1)-(8) of this condition, for which the permittee has obtained a determination from the Department that fugitive emissions from the source, after appropriate control, meet the following requirements:
 - (i) The emissions are of minor significance with respect to causing air pollution; and
 - (ii) The emissions are not preventing or interfering with the attainment or maintenance of any ambient air quality standard.

003 [25 Pa. Code §123.2]**Fugitive particulate matter**

A person may not permit fugitive particulate matter to be emitted into the outdoor atmosphere from a source specified in 25 Pa. Code 123.1, if such emissions are visible at the point the emissions pass outside the person's property.

004 [25 Pa. Code §123.31]**Limitations**

A person may not permit the emission into the outdoor atmosphere of any malodorous air contaminants from any source in such a manner that the malodors are detectable outside the property of the person on whose land the source is being operated.

005 [25 Pa. Code §123.41]**Limitations**

A person may not permit the emission into the outdoor atmosphere of visible air contaminants in such a manner that the opacity of the emission is either of the following:

- (a). Equal to or greater than 20% for a period or periods aggregating more than three minutes in any 1 hour.
- (b). Equal to or greater than 60% at any time.

006 [25 Pa. Code §123.42]**Exceptions**

The limitations of 25 Pa. Code 123.41 shall not apply to a visible emission in any of the following instances:

- (a). When the presence of uncombined water is the only reason for failure to meet the limitations.

**SECTION C. Site Level Requirements**

(b). When the emission results from the operation of equipment used solely to train and test persons in observing the opacity of visible emissions.

(c). When the emission results from the sources specified in 25 Pa. Code §123.1.

007 [25 Pa. Code §127.441]**Operating permit terms and conditions.**

(a) The permittee shall limit the facility wide emissions to the following:

(A) Total VOC emissions to less than 25 tons per year (tpy), calculated as 12-month rolling sums; and

(B) A single HAP emission to less than 10 tpy, and combined HAP emissions to less than 25 tpy, calculated as 12-month rolling sums.

(b) The emissions shall be calculated on a per batch basis using material balance and chemical reactions stoichiometry, then be combined to demonstrate compliance with paragraph (a), above.

008 [25 Pa. Code §129.14]**Open burning operations**

No person may permit the open burning of material in the Southeast Air Basin except where the open burning operations result from:

(a) a fire set to prevent or abate a fire hazard, when approved by the Department and set by or under the supervision of a public officer;

(b) any fire set for the purpose of instructing personnel in fire fighting, when approved by the Department;

(c) a fire set for the prevention and control of disease or pests, when approved by the Department;

(d) a fire set in conjunction with the production of agricultural commodities in their unmanufactured state on the premises of the farm operation;

(e) a fire set for the purpose of burning domestic refuse, when the fire is on the premises of a structure occupied solely as a dwelling by two families or less and when the refuse results from the normal occupancy of the structure;

(f) a fire set solely for recreational or ceremonial purposes; or

(g) a fire set solely for cooking food.

II. TESTING REQUIREMENTS.**# 009 [25 Pa. Code §127.441]****Operating permit terms and conditions.**

(a) If at any time the Department has cause to believe that air contaminant emissions from any source may be in excess of the limitations specified in this Permit, or established pursuant to, any applicable rule or regulation contained in 25 Pa. Code Article III, the permittee shall be required to conduct whatever tests are deemed necessary by the Department to determine the actual emission rate(s).

(b) Such testing shall be conducted in accordance with the provisions of 25 Pa. Code Chapter 139 and the most current version of the DEP Source Testing Manual, when applicable, and in accordance with any restrictions or limitations established by the Department at such time as it notifies the permittee that testing is required.

III. MONITORING REQUIREMENTS.**# 010 [25 Pa. Code §123.43]****Measuring techniques**

Visible emissions may be measured using either of the following:

(1). A device approved by the Department and maintained to provide accurate opacity measurements.

**SECTION C. Site Level Requirements**

(2). Observers, trained and qualified to measure plume opacity with the naked eye or with the aid of any devices approved by the Department.

011 [25 Pa. Code §127.441]**Operating permit terms and conditions.**

(a) The permittee shall monitor the facility, once per operating day, for the following:

- (1) odors which may be objectionable (as per 25 Pa. Code §123.31);
- (2) visible emissions (as per 25 Pa. Code §§123.41 and 123.42); and
- (3) fugitive particulate matter (as per 25 Pa. Code §§ 123.1 and 123.2).

(b) Objectionable odors, fugitive particulate emissions, and visible emissions that are caused or may be caused by operations at the site shall:

- (1) be investigated;
- (2) be reported to the facility management, or individual(s) designated by the permittee;
- (3) have appropriate corrective action taken (for emissions that originate on-site); and
- (4) be recorded in a permanent written log.

(c) After six (6) months of daily monitoring, and upon the permittee's request, the Department will determine the feasibility of decreasing the monitoring frequency to weekly.

(d) After six (6) months of weekly monitoring, and upon the permittee's request, the Department will determine the feasibility of decreasing the frequency of monitoring to monthly.

(e) The Department reserves the right to change the above monitoring requirements at any time, based on but not limited to: the review of the compliance certification (if applicable), complaints, monitoring results, and/or Department findings.

IV. RECORDKEEPING REQUIREMENTS.**# 012 [25 Pa. Code §127.441]****Operating permit terms and conditions.**

The permittee shall maintain a record of all monitoring of fugitive emissions, visible emissions and odors, including those that deviate from the conditions found in this permit. The record of deviations shall contain, at a minimum, the following items:

- (a) date, time, and location of the incident(s);
- (b) the cause of the event; and
- (c) the corrective action taken, if necessary, to abate the situation and prevent future occurrences.

013 [25 Pa. Code §127.441]**Operating permit terms and conditions.**

For each time the facility is monitored for odors, fugitive particulate emissions, and visible emissions, operations personnel shall record their observations and findings.

014 [25 Pa. Code §127.441]**Operating permit terms and conditions.**

The permittee shall maintain records of all the facility's increases of emissions from the following categories:

- (a) emissions increase of minor significance without notification to the Department.
- (b) de minimis increases with notification to the Department, via letter.
- (c) increases resulting from a Request for Determination (RFD) to the Department.
- (d) increases resulting from the issuance of a plan approval and subsequent operating permit.

015 [25 Pa. Code §127.441]**Operating permit terms and conditions.**

The permittee shall keep sufficient records to show compliance with emissions limits in Condition #007 of this section.

**SECTION C. Site Level Requirements****V. REPORTING REQUIREMENTS.****# 016 [25 Pa. Code §127.441]****Operating permit terms and conditions.**

[Additional authority for this permit condition is also derived from 40 CFR Part 68.]

- (a) If required by Section 112(r) of the Clean Air Act, the permittee shall develop and implement an accidental release program consistent with requirements of the Clean Air Act, 40 CFR Part 68 (relating to chemical accident prevention provisions) and the Federal Chemical Safety Information, Site Security and Fuels Regulatory Relief Act (P.L. 106-40).
- (b) The permittee shall prepare and implement a Risk Management Plan (RMP) which meets the requirements of Section 112(r) of the Clean Air Act, 40 CFR Part 68 and the Federal Chemical Safety Information, Site Security and Fuels Regulatory Relief Act when a regulated substance listed in 40 CFR § 68.130 is present in a process in more than the threshold quantity at a facility. The permittee shall submit the RMP to the federal Environmental Protection Agency according to the following schedule and requirements:
- (1) The permittee shall submit the first RMP to a central point specified by EPA no later than the latest of the following:
- (i) Three years after the date on which a regulated substance is first listed under 40 CFR § 68.130; or,
 - (ii) The date on which a regulated substance is first present above a threshold quantity in a process.
- (2) The permittee shall submit any additional relevant information requested by the Department or EPA concerning the RMP and shall make subsequent submissions of RMPs in accordance with 40 CFR § 68.190.
- (3) The permittee shall certify that the RMP is accurate and complete in accordance with the requirements of 40 CFR Part 68, including a checklist addressing the required elements of a complete RMP.
- (c) As used in this permit condition, the term "process" shall be as defined in 40 CFR § 68.3. The term "process" means any activity involving a regulated substance including any use, storage, manufacturing, handling, or on-site movement of such substances or any combination of these activities. For purposes of this definition, any group of vessels that are interconnected, or separate vessels that are located such that a regulated substance could be involved in a potential release, shall be considered a single process.
- (d) If this facility is subject to 40 CFR Part 68, as part of the certification required under this permit, the permittee shall:
- (1) Submit a compliance schedule for satisfying the requirements of 40 CFR Part 68 by the date specified in 40 CFR § 68.10(a); or,
 - (2) Certify that this facility is in compliance with all requirements of 40 CFR Part 68 including the registration and submission of the RMP.
- (e) If this facility is subject to 40 CFR Part 68, the permittee shall maintain records supporting the implementation of an accidental release program for five (5) years in accordance with 40 CFR § 68.200.
- (f) When this facility is subject to the accidental release program requirements of Section 112(r) of the Clean Air Act and 40 CFR Part 68, appropriate enforcement action will be taken by the Department if the permittee fails to register and submit the RMP or a revised plan pursuant to 40 CFR Part 68.

017 [25 Pa. Code §127.441]**Operating permit terms and conditions.**

- (a) The permittee shall report malfunctions, emergencies or incidents of excess emissions to the Department at 484-250-5920. A malfunction is any sudden, infrequent, and not reasonably preventable failure of air pollution control equipment, process equipment, or a process to operate in a normal or usual manner. An emergency is any situation arising from sudden and reasonably unforeseeable events beyond the control of the owner or operator of a facility which requires immediate corrective action to restore normal operation and which causes the emission source to exceed emissions, due to unavoidable increases in emissions attributable to the situation. An emergency shall not include situations caused by improperly designed equipment, lack of preventive maintenance, careless or improper operation, or operator error.

**SECTION C. Site Level Requirements**

(b) When the malfunction, emergency or incident of excess emissions poses an imminent danger to the public health, safety, welfare, or environment, it shall be reported to the Department and the County Emergency Management Agency by telephone within one (1) hour after the discovery of the malfunction, emergency or incident of excess emissions. The owner or operator shall submit a written or emailed report of instances of such malfunctions, emergencies or incidents of excess emissions to the Department within three (3) business days of the telephone report.

(c) The report shall describe the following:

- (1) Name, permit or authorization number, and location of the facility;
- (2) Nature and cause of the malfunction, emergency or incident;
- (3) Date and time when the malfunction, emergency or incident was first observed;
- (4) Expected duration of excess emissions;
- (5) Estimated rate of emissions; and
- (6) Corrective actions or preventative measures taken.

(d) Any malfunction, emergency or incident of excess emissions that is not subject to the notice requirements of paragraph (b) of this condition shall be reported to the Department by telephone within 24 hours (or by 4:00 PM of the next business day, whichever is later) of discovery and in writing or by e-mail within five (5) business days of discovery. The report shall contain the same information required by paragraph (c), and any permit specific malfunction reporting requirements.

(e) During an emergency an owner or operator may continue to operate the source at their discretion provided they submit justification for continued operation of a source during the emergency and follow all the notification and reporting requirements in accordance with paragraphs (b)-(d), as applicable, including any permit specific malfunction reporting requirements.

(f) Reports regarding malfunctions, emergencies or incidents of excess emissions shall be submitted to the appropriate DEP Regional Office Air Program Manager.

(g) Any emissions resulted from malfunction or emergency are to be reported in the annual emissions inventory report, if the annual emissions inventory report is required by permit or authorization.

VI. WORK PRACTICE REQUIREMENTS.**# 018 [25 Pa. Code §123.1]****Prohibition of certain fugitive emissions**

A person responsible for any source specified in Condition #002, above, shall take all reasonable actions to prevent particulate matter from becoming airborne. These actions shall include, but not be limited to, the following

- (a) use, where possible, of water or suitable chemicals, for control of dust in the demolition of buildings or structures, construction operations, the grading of roads, or the clearing of land;
- (b) application of asphalt, water, or other suitable chemicals, on dirt roads, material stockpiles and other surfaces which may give rise to airborne dusts;
- (c) paving and maintenance of roadways; and
- (d) prompt removal of earth or other material from paved streets onto which earth or other material has been transported by trucking or earth moving equipment, erosion by water, or by other means.

019 [25 Pa. Code §127.441]**Operating permit terms and conditions.**

The permittee shall ensure that the source(s) and air pollution control device(s), where applicable, of this permit, are operated and maintained in a manner consistent with good operating and maintenance practices, and in accordance with manufacturer's specifications.

**SECTION C. Site Level Requirements****# 020 [25 Pa. Code §127.441]****Operating permit terms and conditions.**

The permittee shall immediately, upon discovery, implement measures, which may include the application for the installation of an air cleaning device(s), if necessary, to reduce the air contaminant emissions to within applicable limitations, if at any time the operation of the source(s) identified in Section A of this permit, is causing the emission of air contaminants in excess of the limitations specified in, or established pursuant to, 25 Pa. Code Article III, or any other applicable rule promulgated under the Clean Air Act.

021 [25 Pa. Code §127.441]**Operating permit terms and conditions.**

The permittee may not modify any air contaminant system identified in this permit, prior to obtaining Department approval, except those modifications authorized by Condition #013(g) of Section B, of this permit.

VII. ADDITIONAL REQUIREMENTS.

No additional requirements exist except as provided in other sections of this permit including Section B (State Only General Requirements).

VIII. COMPLIANCE CERTIFICATION.

No additional compliance certifications exist except as provided in other sections of this permit including Section B (relating to State Only General Requirements).

IX. COMPLIANCE SCHEDULE.

No compliance milestones exist.

**SECTION D. Source Level Requirements**

Source ID: 101

Source Name: REACTORS

Source Capacity/Throughput:

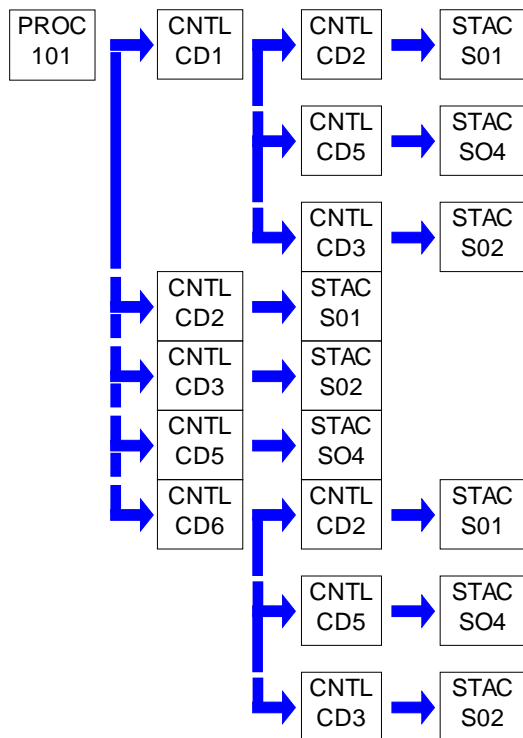
**I. RESTRICTIONS.****Control Device Efficiency Restriction(s).**

001 [25 Pa. Code §127.441]

Operating permit terms and conditions.

A) The scrubbers shall remove ammonia and hydrochloric acid by 99 percent by weight. The permittee shall limit the emissions of ammonia to 0.15 lb/hr and hydrochloric acid to 0.90 lb/hr.

B) The condensers (CD1) shall reduce condensable VOC emissions by 90 percent by weight.

C) The chilled dewar trap (CD6) shall reduce condensable VOC emissions by 99 percent by weight.

II. TESTING REQUIREMENTS.

No additional testing requirements exist except as provided in other sections of this permit including Section B (State Only General Requirements).

III. MONITORING REQUIREMENTS.

002 [25 Pa. Code §127.441]

Operating permit terms and conditions.

A. The permittee shall monitor the outlet temperature of the condensers (CD1) daily, when in operation to ensure that the operating condition achieves at least 90 percent reduction in condensable VOC emissions. The outlet temperature shall be maintained below 40°F except when manufacturing products which are in a solid phase at or above

**SECTION D. Source Level Requirements**

32°F or with a vapor pressure less than 0.1 mm Hg @ 25°C.

B. The permittee shall monitor the temperature of the chilled dewar trap (CD6) daily, when in operation. The temperature of the chilled dewar trap shall be maintained below -25°C (-13°F).

C. The permittee shall monitor the operating parameters for Scrubbers as given under Condition #007(a)-(c) of this source, on a daily basis, when in operation.

IV. RECORDKEEPING REQUIREMENTS.**# 003 [25 Pa. Code §127.441]****Operating permit terms and conditions.**

A. The permittee shall keep records of how much raw materials are fed to each reactor each time and how much products are made from each batch each time.

B. The permittee shall keep records of the outlet temperature of the condenser (CD1) on a daily basis, when in operation.

C. The permittee shall keep records of the temperature of the chilled dewar trap (CD6) on a daily basis, when in operation.

D. The permittee shall keep records of pressure drop, flow rate and pH of the scrubbers, on a daily basis when in operation.

004 [25 Pa. Code §127.441]**Operating permit terms and conditions.**

The permittee shall maintain the following records, on a monthly basis, for the Acid Gas Eductor-Packed Tower Scrubber-manufactured by Duall/Met-Pro, Model No. E2000 when it is not functioning as the primary acid gas scrubber:

A. inspections performed, including instrumentation to monitor the operating pressure drop and water flow rate,

B. maintenance performed,

C. any deficiencies, and

D. any corrective actions taken.

Maintenance records shall be maintained separately from other required recordkeeping.

V. REPORTING REQUIREMENTS.

No additional reporting requirements exist except as provided in other sections of this permit including Section B (State Only General Requirements).

VI. WORK PRACTICE REQUIREMENTS.**# 005 [25 Pa. Code §127.441]****Operating permit terms and conditions.**

The emissions from the reactors covered under this source shall be either recovered or vented as follows:

A. Under vacuum conditions, of products which are in a solid phase at or above 32°F or with a vapor pressure less than 0.1 mm Hg @ 25°C, vent to condensers (CD1 not operational), chilled dewar trap (CD6), vacuum pump and appropriate scrubber mentioned below.

B. Under atmospheric conditions, vent to condensers (CD1), and appropriate scrubber.

C. Under high pressure, the reaction shall be completed, cooled, and blanketed with nitrogen (N₂) and then vented to appropriate scrubbers mentioned below:

i. Acid Gas Spray tower/Eductor Venturis manufactured by Verantis, Model No. SST-30/EVS-16 is to be operated as the

**SECTION D. Source Level Requirements**

primary acid gas scrubber. The Acid Gas Eductor Packed Tower Scrubber manufactured by Duall/Met-Pro, Model No. E2000 is to be operated in the event the Verantis Acid Gas Scrubber is inoperable or

ii. Base Gas packed tower Scrubber-manufactured by Dual/Met-Pro, Model No. PT508-325

The permittee shall operate the scrubbers as follows:

a. For the Acid Gas Scrubbers - When in operation, an operating pressure drop between 2.5 and 6 inches water gauge for the (Duall) and between 1 and 4 inches water gauge for the (Verantis) shall be maintained across the scrubber, and a water flow rate between 200-280 GPM (Duall) and between 285-330 GPM (Verantis) shall be supplied to the scrubber.

Note: For the Duall Scrubber (C02) the (total) pressure drop is the sum of "Demister Pad" and the "Packed Tower" pressures and that the (total) water flow rate is the sum of the "Venturi Supply" and the "Packed Tower" flow rates. The Demister Pad, Packed Tower and Venturi Supply are noted on Gelest's internal records.

b. For the Base Gas Scrubber - When in operation, an operating pressure drop between 2 and 4 inches water gauge shall be maintained across the scrubber and a water flow rate between 40 GPM and 75 GPM shall be supplied to the scrubber.

c. When in operation, the pH concentration of the respective scrubbing solution shall be maintained at:

i. Acid Gas Scrubber - 10 or higher when scrubbing acid gases

ii. Base Gas Scrubber - 3 or lower when scrubbing base gases.

006 [25 Pa. Code §127.441]**Operating permit terms and conditions.**

During the addition of materials to the reactors, the permittee shall pump in or pour materials in a manner that causes low fluid turbulence. The air emission control devices shall be utilized during all other operations.

007 [25 Pa. Code §127.441]**Operating permit terms and conditions.**

On an annual basis, the permittee shall internally inspect the Acid Gas Eductor-Packed Tower Scrubber-manufactured by Duall/Met-Pro, Model No. E2000, when it is not functioning as the primary scrubber, for any material restricting flow.

008 [25 Pa. Code §127.441]**Operating permit terms and conditions.**

Equipment shall be operated so that the following can be measured on a regular basis:

a. Pressure drop between inlet and outlet of each scrubber, utilizing a differential manometer, or equivalent;

b. Water flow rate to each scrubber, utilizing a rotameter, or equivalent.

c. The outlet temperature of the condenser's chilled fluid stream.

d. The operating temperature of the chilled dewar trap.

009 [25 Pa. Code §127.441]**Operating permit terms and conditions.**

The permittee shall place a thermocouple, with a digital display, inside the chilled dewar trap to ensure the trap temperature remains below -25 degrees C (-13 degrees F) as given under Condition #002(b).

010 [25 Pa. Code §127.441]**Operating permit terms and conditions.**

**SECTION D. Source Level Requirements**

Each reactor shall be connected to one chilled dewar trap when used as an alternative to the existing chilled fluid condenser during vacuum distillation of products which are in a solid phase at or above 32°F or with a vapor pressure less than 0.1 mm Hg @ 25°C and to a scrubber.

VII. ADDITIONAL REQUIREMENTS.**# 011 [25 Pa. Code §127.441]****Operating permit terms and conditions.**

Source # 101 contains the following sources:

- (a) Glass lined steel reactor No.1 (500 gallons)
- (b) Glass lined steel reactor No.2 (300 gallons)
- (c) Glass lined steel reactor No.3 (200 gallons)
- (d) Glass lined steel reactor No.4 (100 gallons)
- (e) Glass lined steel reactor No.5 (100 gallons)
- (f) Glass lined steel reactor No.6 (50 gallons)
- (g) Glass lined steel reactor No.7 (30 gallons)
- (h) Glass lined steel reactor No.8 (100 gallons)
- (i) Glass lined steel reactor No.9 (200 gallons)
- (j) Conical Blender/Dryer (21 cu. Ft.)

and the following reactors (Source Id 101A under PA #09-0152D):

Source Name	Location	Capacity (Gallons)
RGS-502	R18	500
RGS-1003	R18	1000
RGS-1004	R18	1000
RSS-130	R14	130
RSS-360	R14	360
RGS-1002	R13	1000

012 [25 Pa. Code §127.441]**Operating permit terms and conditions.**

The Chilled Dewar Trap (CD6) is composed of two dewar traps used in series.

Total Minimum Capacity: two 4-liter traps = 8 liters total.

Total VOC removal efficiency >= 99%.

**SECTION D. Source Level Requirements**

Source ID: 103A

Source Name: EXEMPT EMERGENCY GENERATOR

Source Capacity/Throughput:

**I. RESTRICTIONS.****Emission Restriction(s).****# 001 [25 Pa. Code §123.13]****Processes**

No person may permit the emission into the outdoor atmosphere of particulate matter from this source in excess of 0.04 gr/dscf, pursuant to 25 Pa. Code § 123.13 (c)(1)(i).

002 [25 Pa. Code §123.21]**General**

No person may permit the emission into the outdoor atmosphere of sulfur oxides from this source in a manner that the concentration of the sulfur oxides, expressed as SO₂, in the effluent gas exceeds 500 ppmvd.

003 [25 Pa. Code §127.441]**Operating permit terms and conditions.**

The permittee shall limit the aggregate NO_x emissions from all exempt engines on site to less than 100 lbs/hr, 1000 lbs/day, 2.75 tons per ozone season and 6.6 tons per year on a 12-month rolling basis.

004 [40 CFR Part 63 NESHAPS for Source Categories §40 CFR 63.6640]**Subpart ZZZZ - National Emissions Standards for Hazardous Air Pollutants for Stationary Reciprocating Internal Combustion Engines****How do I demonstrate continuous compliance with the emission limitations, operating limitations, and other requirements?**

The permittee shall:

- i. operating and maintaining the stationary RICE according to the manufacturer's emission-related operation and maintenance instructions; or
- ii. Develop and follow your own maintenance plan which must provide to the extent practicable for the maintenance and operation of the engine in a manner consistent with good air pollution control practice for minimizing emissions.

[40 CFR 63.6640(a) and Table 6 item 9]

Fuel Restriction(s).**# 005 [25 Pa. Code §127.441]****Operating permit terms and conditions.**

The permittee shall fire only:

- 1) No. 2 fuel oil with a maximum sulfur content of 15 ppm (by weight) or
- 2) Diesel fuel with a maximum sulfur content of 15 ppm (by weight).

**SECTION D. Source Level Requirements****Operation Hours Restriction(s).**

006 [25 Pa. Code §127.441]
Operating permit terms and conditions.

Each generator may operate for any of the following purposes: emergency power generation, maintenance, and routine readiness testing.

007 [25 Pa. Code §127.441]
Operating permit terms and conditions.

The permittee shall not operate any of these emergency generators more than 500 hours in any 12 consecutive month period.

008 [40 CFR Part 63 NESHAPS for Source Categories §40 CFR 63.6640]
Subpart ZZZZ - National Emissions Standards for Hazardous Air Pollutants for Stationary Reciprocating Internal Combustion Engines
How do I demonstrate continuous compliance with the emission limitations, operating limitations, and other requirements?

- (a) The permittee shall operate the emergency stationary R.I.C.E. according to the requirements in the most recent version of 40 C.F.R. Section 63.6640(f).
- (b) If the permittee does not operate the engine according to the requirements of 40 C.F.R. Section 63.6640(f), the engine will not be considered an emergency engine under 40 C.F.R. Part 63 Subpart ZZZZ and must meet all requirements for non-emergency engines.

II. TESTING REQUIREMENTS.

No additional testing requirements exist except as provided in other sections of this permit including Section B (State Only General Requirements).

III. MONITORING REQUIREMENTS.

009 [25 Pa. Code §127.441]
Operating permit terms and conditions.

- (1) The permittee shall monitor daily, when operating
- (a) Date of operation.
 (b) Amount of fuel consumed
- (2) The permittee shall calculate NOx emissions monthly and twelve (12) month rolling sum using the emission factors showing compliance with Condition

IV. RECORDKEEPING REQUIREMENTS.

010 [25 Pa. Code §127.441]
Operating permit terms and conditions.

- (1) The permittee shall keep daily records, when in operation
- (a) Date of operation.
 (b) Amount of fuel consumed
 (c) Hours of operation
 (d) Reason for operating

**SECTION D. Source Level Requirements**

(2) The permittee shall keep monthly NOx emission calculations as well as twelve (12) month rolling sum.

011 [25 Pa. Code §127.441]**Operating permit terms and conditions.**

The permittee shall maintain monthly records of the aggregate NOx emissions from all exempt engines on site including pounds per hour, pounds per day, ozone season (i.e., the period from May 1 through September 30 of each year) sums, and 12-month rolling sums to demonstrate compliance with the NOx emission limits applicable to this source.

012 [40 CFR Part 63 NESHAPS for Source Categories §40 CFR 63.6655]**Subpart ZZZZ - National Emissions Standards for Hazardous Air Pollutants for Stationary Reciprocating Internal Combustion Engines****What records must I keep?**

The permittee shall keep records of the hours of operation of the engine that is recorded through the non-resettable hour meter. The permittee must document how many hours are spent for emergency operation, including what classified the operation as emergency and how many hours are spent for non-emergency operation. If the engines are used for demand response operation, the owner or operator must keep records of the notification of the emergency situation, and the time the engine was operated as part of demand response.

[40 CFR 63.6655(f)]

013 [40 CFR Part 63 NESHAPS for Source Categories §40 CFR 63.6655]**Subpart ZZZZ - National Emissions Standards for Hazardous Air Pollutants for Stationary Reciprocating Internal Combustion Engines****What records must I keep?**

The permittee shall keep records of the maintenance conducted on the stationary RICE in order to demonstrate that you operated and maintained the stationary RICE and after-treatment control device (if any) according to your own maintenance plan.

[40 CFR 63.6655(e)]

V. REPORTING REQUIREMENTS.

No additional reporting requirements exist except as provided in other sections of this permit including Section B (State Only General Requirements).

VI. WORK PRACTICE REQUIREMENTS.**# 014 [40 CFR Part 63 NESHAPS for Source Categories §40 CFR 63.6603]****Subpart ZZZZ - National Emissions Standards for Hazardous Air Pollutants for Stationary Reciprocating Internal Combustion Engines****What emission limitations, operating limitations, and other requirements must I meet if I own or operate an existing stationary RICE located at an area source of HAP emissions?**

The permittee shall:

- Change oil and filter every 500 hours of operation or annually, whichever comes first;
- Inspect air cleaner every 1,000 hours of operation or annually, whichever comes first, and replace as necessary; and
- Inspect all hoses and belts every 500 hours of operation or annually, whichever comes first, and replace as necessary.

The permittee has the option of utilizing an oil analysis program in order to extend the specified oil change requirement. The

**SECTION D. Source Level Requirements**

oil analysis must be performed at the same frequency specified for changing the oil. The analysis program must at a minimum analyze the following three parameters: Total Base Number, viscosity, and percent water content. The condemning limits for these parameters are as follows: Total Base Number is less than 30 percent of the Total Base Number of the oil when new; viscosity of the oil has changed by more than 20 percent from the viscosity of the oil when new; or percent water content (by volume) is greater than 0.5. If all of these condemning limits are not exceeded, the permittee is not required to change the oil. If any of the limits are exceeded, the permittee must change the oil within 2 business days of receiving the results of the analysis; if the engine is not in operation when the results of the analysis are received, the permittee must change the oil within 2 business days or before commencing operation, whichever is later. The permittee must keep records of the parameters that are analyzed as part of the program, the results of the analysis, and the oil changes for the engine. The analysis program must be part of the maintenance plan for the engine.

If an emergency engine is operating during an emergency and it is not possible to shut down the engine in order to perform the management practice requirements on the schedule required in items a, b and c above, or if performing the management practice on the required schedule would otherwise pose an unacceptable risk under Federal, State, or local law, the management practice can be delayed until the emergency is over or the unacceptable risk under Federal, State, or local law has abated. The management practice should be performed as soon as practicable after the emergency has ended or the unacceptable risk under Federal, State, or local law has abated. Sources must report any failure to perform the management practice on the schedule required and the Federal, State or local law under which the risk was deemed unacceptable.

[40 CFR 6603(a), 40 CFR 63.6625(i) and footnote to Table 2d]

015 [40 CFR Part 63 NESHAPS for Source Categories §40 CFR 63.6605]

Subpart ZZZZ - National Emissions Standards for Hazardous Air Pollutants for Stationary Reciprocating Internal Combustion Engines

What are my general requirements for complying with this subpart?

The engine must be in compliance with the requirements of Subpart ZZZZ at all times and must operate and maintain the source, including associated air pollution control equipment and monitoring equipment, in a manner consistent with safety and good air pollution control practices for minimizing emissions.

[40 CFR 63.6605(a)&(b)]

016 [40 CFR Part 63 NESHAPS for Source Categories §40 CFR 63.6625]

Subpart ZZZZ - National Emissions Standards for Hazardous Air Pollutants for Stationary Reciprocating Internal Combustion Engines

What are my monitoring, installation, operation, and maintenance requirements?

The permittee shall minimize each engine's time spent at idle during startup, and minimize the engine's startup time to a period needed for appropriate and safe loading of the engine, not to exceed thirty (30) minutes.

017 [40 CFR Part 63 NESHAPS for Source Categories §40 CFR 63.6625]

Subpart ZZZZ - National Emissions Standards for Hazardous Air Pollutants for Stationary Reciprocating Internal Combustion Engines

What are my monitoring, installation, operation, and maintenance requirements?

[Additional authority for this condition is also derived from 40 C.F.R. § 63.6625(f)]

The permittee shall operate and maintain a non-resettable hour meter on this generator.

018 [40 CFR Part 63 NESHAPS for Source Categories §40 CFR 63.6625]

Subpart ZZZZ - National Emissions Standards for Hazardous Air Pollutants for Stationary Reciprocating Internal Combustion Engines

What are my monitoring, installation, operation, and maintenance requirements?

The permittee shall operate and maintain the stationary RICE and after-treatment control device (if any) according to the

**SECTION D. Source Level Requirements**

manufacturer's emission-related written instructions or develop your own maintenance plan which must provide to the extent practicable for the maintenance and operation of the engine in a manner consistent with good air pollution control practice for minimizing emissions.

[40 CFR 63.6625(e)]

VII. ADDITIONAL REQUIREMENTS.

019 [25 Pa. Code §127.441]

Operating permit terms and conditions.

This source is composed of one (1) Cummins, 469 HP engine, Model No. DFCC 5007134, installed in 2002 and manufacture in January 2002.

**SECTION D. Source Level Requirements**

Source ID: 103B

Source Name: TWO EXEMPT EMERGENCY GENERATORS

Source Capacity/Throughput:

**I. RESTRICTIONS.****Emission Restriction(s).****# 001 [25 Pa. Code §123.13]****Processes**

No person may permit the emission into the outdoor atmosphere of particulate matter from this source in excess of 0.04 gr/dscf, pursuant to 25 Pa. Code § 123.13 (c)(1)(i).

002 [25 Pa. Code §123.21]**General**

No person may permit the emission into the outdoor atmosphere of sulfur oxides from this source in a manner that the concentration of the sulfur oxides, expressed as SO₂, in the effluent gas exceeds 500 ppmvd.

003 [25 Pa. Code §127.441]**Operating permit terms and conditions.**

The permittee shall limit the aggregate NO_x emissions from all exempt engines on site to less than 100 lbs/hr, 1000 lbs/day, 2.75 tons per ozone season and 6.6 tons per year on a 12-month rolling basis.

004 [40 CFR Part 60 Standards of Performance for New Stationary Sources §40 CFR 60.4205]**Subpart III - Standards of Performance for Stationary Compression Ignition Internal Combustion Engines****What emission standards must I meet for emergency engines if I am an owner or operator of a stationary CI internal co**

This source shall comply with the following emission standards for new nonroad CI engines:

EG2 (169 HP, 126.0 kW) NMHC: 4.0 g/kW-hr CO: 5.0 g/kW-hr PM: 0.30 g/kW-hr

EG2 (335 HP, 249.8 kW) NMHC: 4.0 g/kW-hr CO: 3.5 g/kW-hr PM: 0.20 g/kW-hr

[40 CFR 60.4202, and 40 CFR 89.112 Table 1]

Fuel Restriction(s).**# 005 [25 Pa. Code §127.441]****Operating permit terms and conditions.**

The permittee shall only fire No. 2 fuel oil, with a maximum sulfur content of 15ppm (by weight).

006 [40 CFR Part 60 Standards of Performance for New Stationary Sources §40 CFR 60.4207]**Subpart III - Standards of Performance for Stationary Compression Ignition Internal Combustion Engines****What fuel requirements must I meet if I am an owner or operator of a stationary CI internal combustion engine subject to**

**SECTION D. Source Level Requirements**

The diesel fuel used in this source must meet the following requirements:

- (1) Sulfur content.
 - (i) 15 ppm maximum for NR diesel fuel.
- (2) Cetane index or aromatic content, as follows:
 - (i) A minimum cetane index of 40; or
 - (ii) A maximum aromatic content of 35 volume percent.

[60 CFR 60.4207(b) and 40 CFR 80.510(b)]

Operation Hours Restriction(s).

007 [25 Pa. Code §127.441]

Operating permit terms and conditions.

Each generator may operate for any of the following purposes: emergency power generation, maintenance, and routine readiness testing.

008 [25 Pa. Code §127.441]

Operating permit terms and conditions.

The permittee shall not operate any of these emergency generators more than 500 hours in any 12 consecutive month period.

009 [40 CFR Part 60 Standards of Performance for New Stationary Sources §40 CFR 60.4211]

Subpart III - Standards of Performance for Stationary Compression Ignition Internal Combustion Engines**What are my compliance requirements if I am an owner or operator of a stationary CI internal combustion engine?**

- (a) The permittee shall operate the emergency stationary R.I.C.E. according to the requirements in the most recent version of 40 C.F.R. Section 60.4211(f).
- (b) If the permittee does not operate the engine according to the requirements of 40 C.F.R. Section 60.4211(f), the engine will not be considered an emergency engine under 40 C.F.R. Part 60 Subpart III and must meet all requirements for non-emergency engines.

II. TESTING REQUIREMENTS.

No additional testing requirements exist except as provided in other sections of this permit including Section B (State Only General Requirements).

III. MONITORING REQUIREMENTS.

010 [25 Pa. Code §127.441]

Operating permit terms and conditions.

- (1) The permittee shall monitor daily, when operating
 - (a) Date of operation.
 - (b) Amount of fuel consumed
 - (c) Hours of operation
 - (d) Reason for operating
- (2) The permittee shall calculate NO_x emissions monthly and twelve (12) month rolling sum using the emission factors

**SECTION D. Source Level Requirements**

showing compliance with Condition

IV. RECORDKEEPING REQUIREMENTS.**# 011 [25 Pa. Code §127.441]****Operating permit terms and conditions.**

(1) The permittee shall keep daily records, when in operation

- (a) Date of operation.
- (b) Amount of fuel consumed
- (c) Hours of operation
- (d) Reason for operating

(2) The permittee shall keep monthly NOx emission calculations as well as twelve (12) month rolling sum.

012 [25 Pa. Code §127.441]**Operating permit terms and conditions.**

The permittee shall maintain monthly records of the aggregate NOx emissions from all exempt engines on site including pounds per hour, pounds per day, ozone season (i.e., the period from May 1 through September 30 of each year) sums, and 12-month rolling sums to demonstrate compliance with the NOx emission limits applicable to this source.

013 [40 CFR Part 60 Standards of Performance for New Stationary Sources §40 CFR 60.4214]**Subpart III - Standards of Performance for Stationary Compression Ignition Internal Combustion Engines****What are my notification, reporting, and recordkeeping requirements if I am an owner or operator of a stationary CI internal combustion engine?**

The permittee shall keep records of the operation of the engine in emergency and non-emergency service that are recorded through the non-resettable hour meter. The permittee must record the time of operation of the engine and the reason the engine was in operation during that time.

V. REPORTING REQUIREMENTS.

No additional reporting requirements exist except as provided in other sections of this permit including Section B (State Only General Requirements).

VI. WORK PRACTICE REQUIREMENTS.**# 014 [40 CFR Part 60 Standards of Performance for New Stationary Sources §40 CFR 60.4209]****Subpart III - Standards of Performance for Stationary Compression Ignition Internal Combustion Engines****What are the monitoring requirements if I am an owner or operator of a stationary CI internal combustion engine?**

The permittee shall install a non-resettable hour meter on each engine.

015 [40 CFR Part 60 Standards of Performance for New Stationary Sources §40 CFR 60.4211]**Subpart III - Standards of Performance for Stationary Compression Ignition Internal Combustion Engines****What are my compliance requirements if I am an owner or operator of a stationary CI internal combustion engine?**

The permittee shall:

- (1) Operate and maintain the stationary CI internal combustion engine and control device according to the

**SECTION D. Source Level Requirements**

manufacturer's emission-related written instructions;
 (2) Change only those emission-related settings that are permitted by the manufacturer; and
 (3) Meet the requirements of 40 CFR parts 89, 94 and/or 1068, as they apply to you.

[40 CFR 60.4211(a)]

**# 016 [40 CFR Part 60 Standards of Performance for New Stationary Sources §40 CFR 60.4211]
 Subpart IIII - Standards of Performance for Stationary Compression Ignition Internal Combustion Engines
 What are my compliance requirements if I am an owner or operator of a stationary CI internal combustion engine?**

The permittee shall comply with the emission standards specified in Condition #001 by purchasing an engine certified to the emission standards in §60.4205(b) for the same model year and maximum engine power. The engine must be installed and configured according to the manufacturer's emission-related specifications, except as permitted in 40 CFR 60.4211(g).

[40 CFR 60.4211(c)]

VII. ADDITIONAL REQUIREMENTS.

**# 017 [25 Pa. Code §127.441]
 Operating permit terms and conditions.**

This source is composed of the following two (2) Cummins, engines:

- (1) 169 HP, Model No. DSGAB 7290897, installed in 2012 and manufacture in June 2011.
- (2) 335 HP, Model No. DQDAA 1522075, installed in 2015 and manufacture in September 2015.



SECTION E. Source Group Restrictions.



SECTION F. Alternative Operation Requirements.

No Alternative Operations exist for this State Only facility.

**SECTION G. Emission Restriction Summary.**

Source Id	Source Description
101	REACTORS

Emission Limit	Pollutant
0.150 Lbs/Hr	Ammonia
0.900 Lbs/Hr	Hydrochloric Acid

Site Emission Restriction Summary

Emission Limit	Pollutant
9.990 Tons/Yr	Single HAP on a 12-month rolling sum Hazardous Air Pollutants
24.990 Tons/Yr	Total VOC on a 12-month rolling sum VOC
24.990 Tons/Yr	Total HAPs on a 12-month rolling sum Hazardous Air Pollutants



SECTION H. Miscellaneous.

(a) Exempted sources: The permittee shall limit the 3 stainless steel reactors in room R-13 to less than 2.7 tons per year to maintain the exemption status as required in RFD # 09-A01-1137 dated August 06, 2007, RFD # 5050 dated May 29, 2015, and RFD # 5424 dated November 4, 2015.

*** February 2022 *** RSS-1001 was removed and replaced by RHS-751 and mixer was moved to Progress via RfD. As a result, the only remaining stainless steel reactor that was included in RfD #09-A01-1137 is RSS-150 ***

- Insignificant source RGS-202 located in R12/22 RGS-202 previously approved by RFD #1968.
- Insignificant sources located in the CSTM building that include small ribbon and conical-type blenders and hammer mills.
- Insignificant sources located in the Band 4 building that include autoclaves ranging in size from 1 to 5 gallons and various reactors ranging in size from 1 to 5 gallons located in the Band 4 building.
- Insignificant sources located in R13 that include various reactors ranging from 100 to 1000 gallons.
- Insignificant sources located in R16 that include various reactors ranging from 5 to 100 liters.

(b) The following insignificant sources have been exempted from the testing, monitoring, recordkeeping, and reporting requirements, however, they are still subject to conditions in Section B and C of this permit:

* Reactors of various sizes ranging from 1 to 200 gallons in room R12/22, R14, R16 & R17, Autoclaves ranging from 1 gal to 360 gal, Separators and Rotating evaporators, conical dryer of 2 cubic feet.

(c) Plan Approval No. 09-0152A is incorporated with all terms and conditions in this State Only Operating Permit.

(d) Plan Approval No. 09-0152B is incorporated with all terms and conditions in this State Only Operating Permit.

(e) Plan Approval No. 09-0152C (Auth # 996193) is incorporated with all terms and conditions in this State Only Operating Permit.

(f) March 2016 APS: 665850, AUTH: 1067314, the Department renewed the facility-wide Operating Permit

(g) Auth: 1206646. Plan Approval No. 09-0152D has been incorporated in its entirety into the operating permit.

(h) As of March 10, 2016, the facility has been granted for weekly monitoring under Condition #011, Section C of this permit until further determination.

***** September 2021 *****

(i) Minor Operating Permit Modification, APS: 665850, AUTH ID: 1365238, PF ID: 570403

The following changes have been made in this Minor Modification:

- 1) Reactivation of the Dual acid gas in scrubber (CD2) Source ID 101 as the backup scrubber to the primary Verantis acid gas scrubber (CD5) with added recordkeeping requirements.
- 2) Temporarily removed Malfunction condition from Section B and added to Section C. Also, 25 Pa. Code § 135.3 has been removed from Section C, it is now in Section B, Condition #023.

***** February 2022 *****

(j) Synthetic Operating Permit Renewal, APS: 665850, AUTH ID: 1320424, PF ID: 570403

The following changes have been made in this renewal:

- 1) Source ID 101: Source Name changed from "REACTORS & A CONICAL BLENDER/DRYER" to "REACTORS".
- 2) Source ID 101: Glass lined steel reactor No.7 (30 gallons) RGS-031 (R-14) removed. It was originally included by mistake.
- 3) Source ID 101: Reactor RSS-360 removed (RfD #9154).
- 4) Source ID 101: Conical Blender/Dryer (21 cu. Ft.) removed. It was relocated to the Progress Drive site under Plan Approval 09-0243.
- 5) Source ID 102: Removed from facility and permit. Site-wide PM emission limit of 0.22 tpy removed because it was associated with Source ID 102 only.
- 6) Source ID 103A & B: Added for 3 existing exempt engines.
- 7) The following sources found to be exempt by RfD are being placed in the Miscellaneous section of the permit:
 - RGS-503: 500 gallon glass-lined reactor, located in R-13, (RfD #5667)
 - RHS-751: 750 gallon Hastelloy, located in R-13, (RfD #6289)
 - Two 9,000 gallon aboveground, pressurized stainless steel tanks, (RfD #6792)
 - RGS-032: 30 gallon glass-lined steel reactor, located in R-25, (RfD #6941)
 - RGS-052: 50-gallon glass-lined steel reactor, located in R-12, (RfD #8618)
 - PBR-002: packed bed reactor train, located in building 7, (RfD #8684)
 - RSS-152: 150 gallon stainless steel distillation unit, located in Building 7, (RfD #8684)
 - RHS-1005: one 1000-gallon Hastelloy high-pressure reactor, located in R-24, (RfD #9154)



SECTION H. Miscellaneous.

***** February 2023 *****

(k) Incorporation of Plan Approval 09-0152E, APS: 665850, AUTH ID: 1422804, PF ID: 570403



***** End of Report *****
